

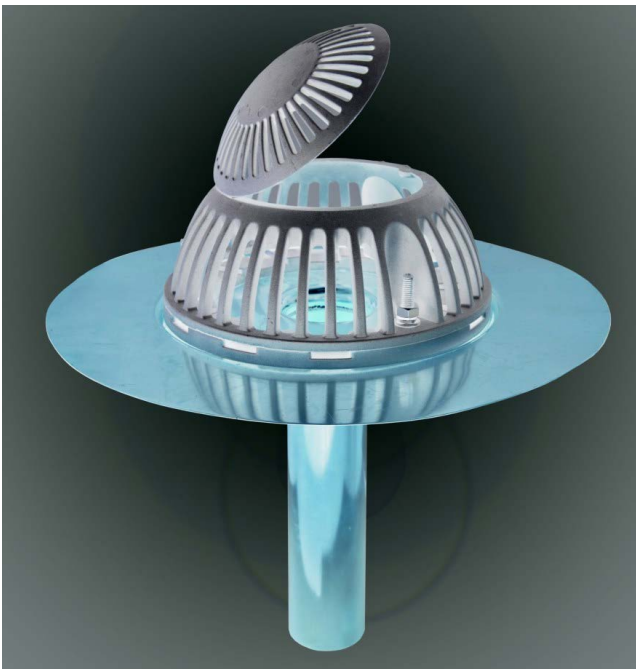

## TFS AD3 ALUMINUM DRAIN *data sheet*

### Dome & Clamping Ring :

- Heavy Duty Casting Aluminum Alloy
- Selection of Fixed and Gated domes for simplicity or easy access
- 9 drainage channels for complete drainage
- Flange designed for optimum sealing
- Universal design fits all TFS drains



### Drain Flange & Stem :

- .080 Spun Aluminum premium grade
- Never-Break-A-Bolt design, Three Aluminum bolt and nut design
- Available in flat and recessed flange
- Cast Aluminum Dome and Clamping Ring
- Double Seam MIG Weld (Spun Aluminum)
- Never-Break Bolt Design
- Aluminum Nut

### Available Size:

- Retrofit: 2 3/4", 3 3/4", 4 3/4", 5 3/4"
- New Construction: 3", 4", 5", 6"

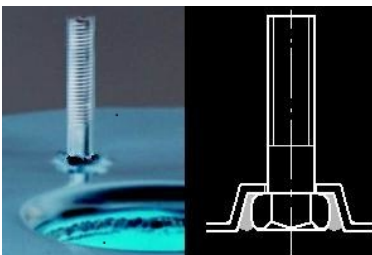

*Never Break  
Bolt Again!*

## 2.75" RETRO FLAT DRAIN

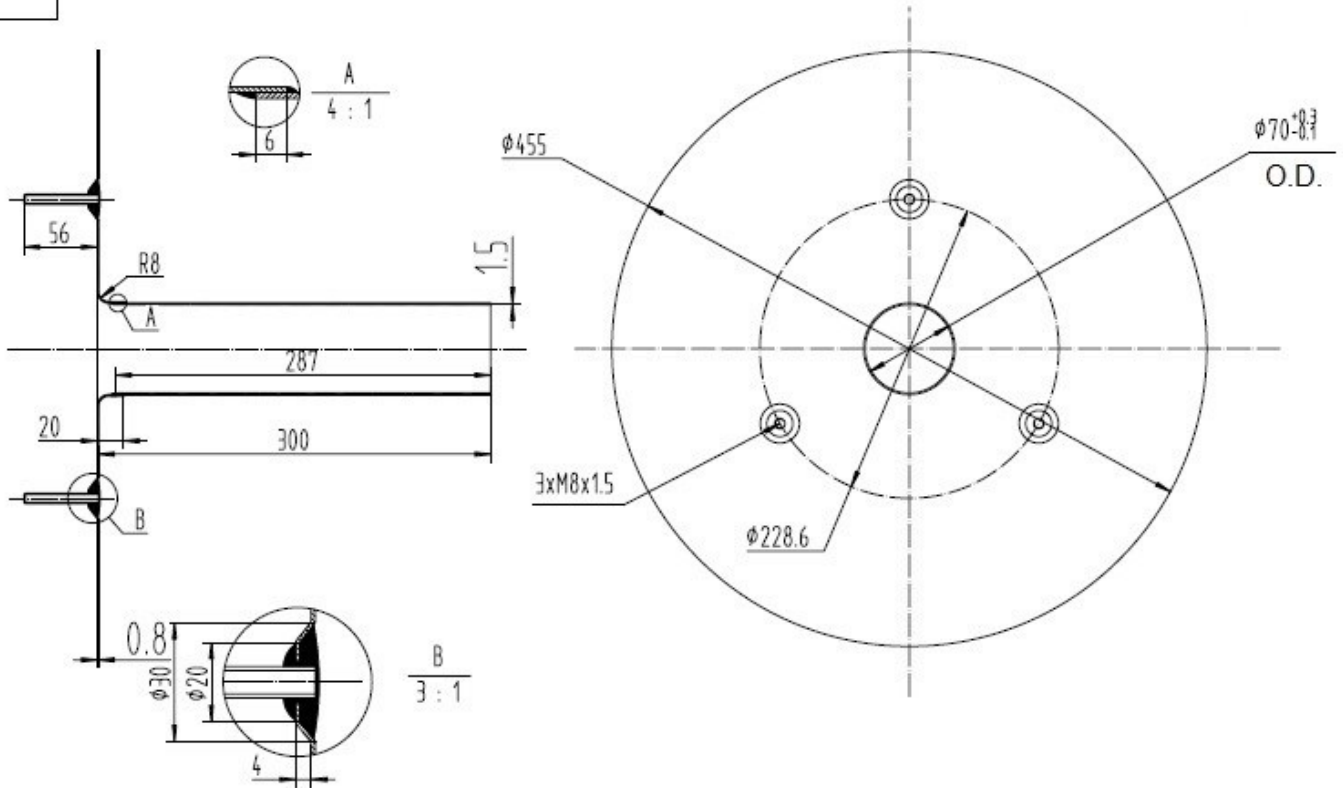

## 3.75" RETRO RECESSED DRAIN

